

**General Recommendations for  
Improved Building Practices in Earthquake and Hurricane Prone Areas**

Recommandations générales pour une meilleure construction  
en régions cycloniques et sismiques

**Prepared in the aftermath of the Haiti earthquake of 2010 for**  
(Préparé à la suite du tremblement de terre de 2010 en Haiti pour)

**Architecture for Humanity**  
(Architecture pour l'Humanité)

848 Folsom Street - Suite 201  
San Francisco, California 94107  
USA  
[www.architectureforhumanity.org](http://www.architectureforhumanity.org)

**By (par)**

Rima Taher, PhD

University Lecturer (Conférencière)  
New Jersey Institute of Technology  
College of Architecture & Design  
University Heights,  
Newark, New Jersey 07102  
USA  
[www.njit.edu](http://www.njit.edu)

E-mail: [Taher@adm.njit.edu](mailto:Taher@adm.njit.edu)

**Preface and Acknowledgments**

This document was prepared for “Architecture for Humanity” in the aftermath of the 2010 Haiti earthquake. It is intended to provide some general recommendations for improved building practices in earthquake and hurricane prone areas, to be used as a resource for builders as they begin their reconstruction efforts in Haiti. The goal in writing this manual is to convey these design and construction guidelines in a pictorial and simple manner. Complex engineering methods and detailed technical discussions were omitted for this purpose.

In providing these general construction guidelines for hazard prone areas, I tried to include some recent research findings mainly from a research work that I carried out at New Jersey Institute of Technology, College of Architecture & Design, in cooperation with CSTB, Centre Scientifique et Technique du Bâtiment (Center for Building Science and Technology), Department of Aerodynamics and Climatic Engineering, of Nantes, France ([www.cstb.fr](http://www.cstb.fr)), on the topic of building design for extreme wind events and hurricanes.

I wish to thank my colleagues from the San Francisco chapter of Architecture for Humanity (AFH), with whom I worked on this project, Miss Kelsey Ochs, Mr. Karl Johnson, and Miss Michelle Nelson, for their help and input. Their dedication to the mission of AFH is admirable.

I also wish to thank the College of Architecture & Design at NJIT and Dean Urs Gauchat, for allowing me to participate in this work. My sincere thanks are equally addressed to the CSTB center at Nantes and its Director, Mr. Jean-Michel Axès, as well as Mr. Bruno Mesureur, Director of International Relations at CSTB, for their help and permission to use some of their illustrations from the cooperative research on hurricane-resistant design.

Rima Taher, PhD

**Contents**

1- Introduction	p. 4
2- Wind Pressure Distribution on a Building	p. 5
3- General Recommendations:	p. 6
3.1 Building Forms	p. 6
3.2- Roof Shapes and Slopes for Hurricanes	P. 10
3.3- Construction Materials and Methods	P. 13
3.4- Foundation Systems for Coastal Areas	P. 16
3.5 – Jobsite Safety Issues	P. 18
3.6 – Sustainability	P. 19
4- References	P. 20

**Sommaire**

1- Introduction	P. 4
2- Distribution des charges de vent sur les surfaces d'un bâtiment	P. 5
3- Recommendations générales	P. 6
3.1- Formes de bâtiment	P. 6
3.2- Formes et pentes de toiture en zones cycloniques	P. 10
3.3- Matériaux et méthodes de construction	P. 13
3.4- Systèmes de fondation en régions littorales	P. 16
3.5- Mesures de sécurité à prendre sur chantier	P. 18
3.6- Écologie en construction	P. 19
4- Références	P. 20

## **General Recommendations for Improved Building Practices in Earthquake and Hurricane Prone Areas**

### **1- Introduction**

Earthquakes are the most feared of all natural disasters. They hit with practically no warning and could cause a tremendous amount of damage in just a few seconds. Hurricanes and extreme wind events are not as unpredictable as earthquakes. They tend to occur more frequently, sometimes affecting large geographic areas.

The cause of earthquakes is believed to be due to the tectonic plates which form the earth's crust. These plates are generally floating and moving, and they occasionally collide causing friction and strain to build up between these plates leading eventually to eruptions in the form of earthquakes. Shock waves propagate through the soil causing the ground to vibrate. Structures built on that ground are in turn subjected to vibration and ground motion, and may as a result either partially or totally collapse.

Buildings and structures built according to the seismic design provisions of the building codes will normally have a sufficient resistance to ground shaking and vibrations, and could survive some large earthquakes without failure.

Hurricanes are tropical storms in which wind speeds equal or exceed 74 mph (119 km/h). A hurricane is characterized by the rising of warm air near the center and the sinking of cool air outside, thus creating rotating winds of very high velocity. On the Saffir/Simpson hurricane scale, numbers range from 1 to 5. Intensity 5 applies to maximum sustained winds of 155 mph (249 km/h) or more, and a potential of storm-surge of more than 18 ft (5.5 m) above normal. A hurricane could cover a geographic area with a diameter of 500 mi (805 km) or more, and is generally accompanied by heavy rains.

A structure exposed to a hurricane is generally subjected to extreme wind loads, and different levels of flooding, surge and battering by water and airborne debris. The storm surge could have a great effect on structures built along the coast line.

In the engineering design methods, there are some general similarities between wind design and earthquake design. Simplified calculation methods treat both seismic forces and wind forces as lateral forces applied to structures. These forces are however calculated differently. Structural systems for buildings in seismic design are similar to those used for wind design, and are both referred to as "lateral load resisting systems".

The ultimate goal of the US building codes is the protection of building occupants and life. The concept of a building damage due to an earthquake is acceptable provided that the damage is repairable. A building should not collapse in the event of a major earthquake.

On the other hand, US building codes do not require that structures be designed for both wind and seismic loads simultaneously. Both forces are calculated and buildings are designed for the larger ones due to the remote possibility of structures being subjected to both types of events at the same time.

## **2- Wind Pressure Distribution on a Building**

The wind pressure distribution on a building envelope is very complex. Generally, on a building with a rectangular plan form, windward walls are under high inward pressure, called positive pressure. This pressure decreases near the edges of the windward walls. The leeward wall experiences outward pressure or suction, called negative pressure. This pressure is higher near the edges and decreases near the center of the wall.

There are normally drag forces on surfaces that are parallel to the wind direction. Corners receive a relatively large outward pressure. A flat roof experiences an outward pressure or uplift, in addition to some drag forces. The pressure on a pitched roof varies depending on different factors such as the pitch of the roof and the building dimensions (Figure 1).

Eaves and overhangs are affected by entrapped wind underneath them which leads to a pressure stagnation on them.

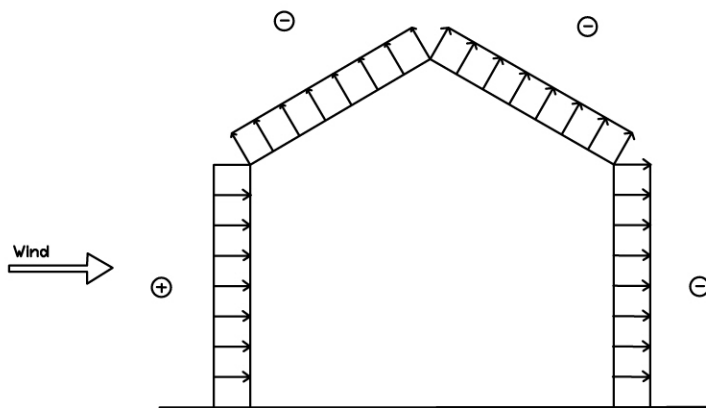

Figure 1

General Wind Pressure Distribution on Building Surfaces  
Distribution générale des charges du vent sur les surfaces d'un bâtiment

### **3- General Recommendations**

In order to keep this document simple and easy to understand, discussions of engineering methods and systems used to design for wind and seismic forces are omitted. Some recommended design and construction practices are summarized below that could help improve the quality of design and construction in hazard prone areas. These guidelines are general and address mainly concrete construction which is often the prevailing type of construction in many of these hazard prone regions of the world. Guidelines relate to:

- 1- Building forms.
- 2- Roof shapes and slopes for hurricanes.
- 3- Construction materials and methods.
- 4- Foundation systems for coastal areas.
- 5- Jobsite safety issues.
- 6- Sustainability.

#### **3.1- Building Forms**

- Design buildings and structures that are regular, with no important discontinuities. Discontinuities in both plan and elevation must be avoided, and relate to both geometry and building stiffness.
- If a building should include masses of different sizes, then it is necessary to completely separate these masses and disconnect their structural systems. This is referred to as a seismic separation (Figure 2).

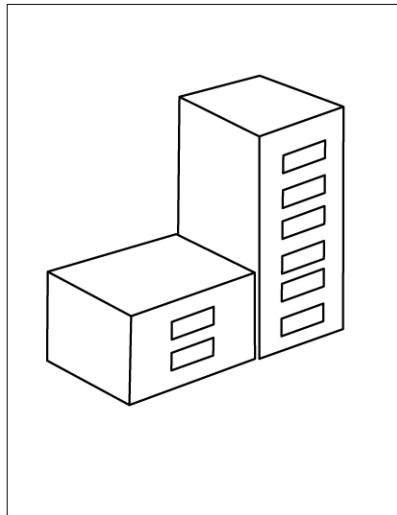

Figure 2

Masses of Different Sizes – Use a Seismic Separation

Masses de tailles différentes – Utiliser une séparation sismique

- Avoid L-, T-, U- and cross-shaped building plans (Figure 3). These corners are known as “reentrant corners” and are generally weak and need strengthening, by adding horizontal structural elements to transfer loads from the corner to the other side of a building. These elements are called “collectors or drag struts”. Building masses could also be separated at these corners.

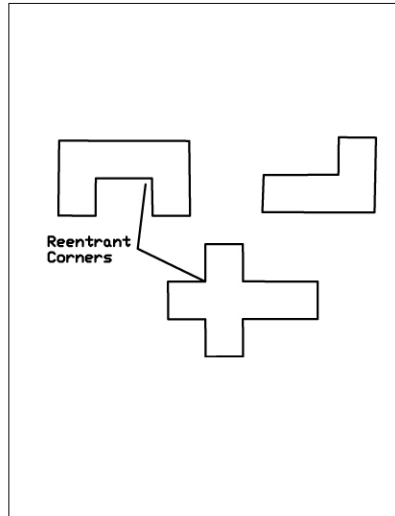

Figure 3

Building Plan Configurations to Avoid in Seismic Areas  
Plans de bâtiments à éviter en régions sismiques

- Building slabs often act as “diaphragms” receiving the lateral forces of wind or earthquake and transferring them to the walls attached to them. In turn, these walls are designed as “shear walls” with the function of transmitting the loads down to the foundation system. For this reason, avoid large openings in slabs acting as “diaphragms”.
- Walls acting as “shear walls” should be made continuous to the foundation, in order to properly transfer all loads to the building foundation. Shear walls should not be interrupted and should not be offset, as this would interrupt the load path. Also, avoid large openings in shear walls (Figure 4).

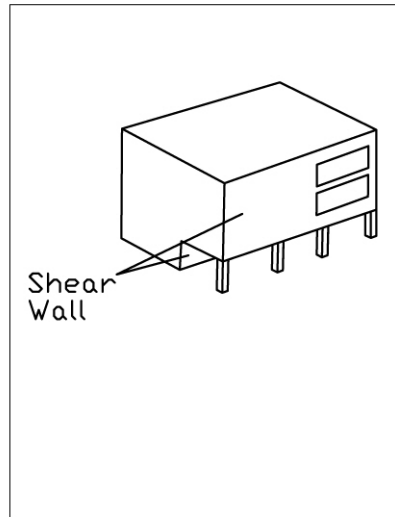

Figure 4

Shear Wall Offset and Large Openings to Avoid

Éviter les interruptions et grandes ouvertures dans les refends porteurs de forces latérales

- Avoid building elevation forms that are thinner at the bottom and wider at the top. A bottom-heavy building is more stable than a top-heavy building (Figure 5). For the same reason, place heavy loads in the lower levels of a building, and avoid locating them on the roof or near the top in a building. Such heavy loads and equipments include water tanks and air-conditioning units.

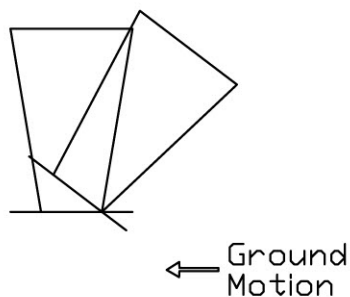

Figure 5

Top-Heavy Buildings Are Less Stable and Could Overturn

Un bâtiment disproportionné et lourd en haut est instable et peut être renversé

- Buildings supported on columns in their first story should have these columns stiffened by bracing (Figure 6).

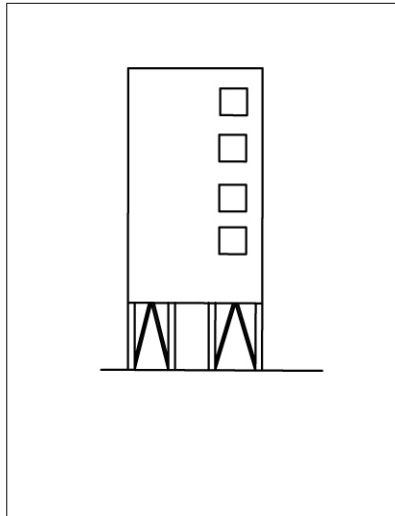

Figure 6  
Ground Floor Soft Story Columns Must Be Braced  
Les poteaux supportant un bâtiment doivent être fortifiés

- Brace building frames with diagonal or chevron bracing (Figures 7a and 7b).

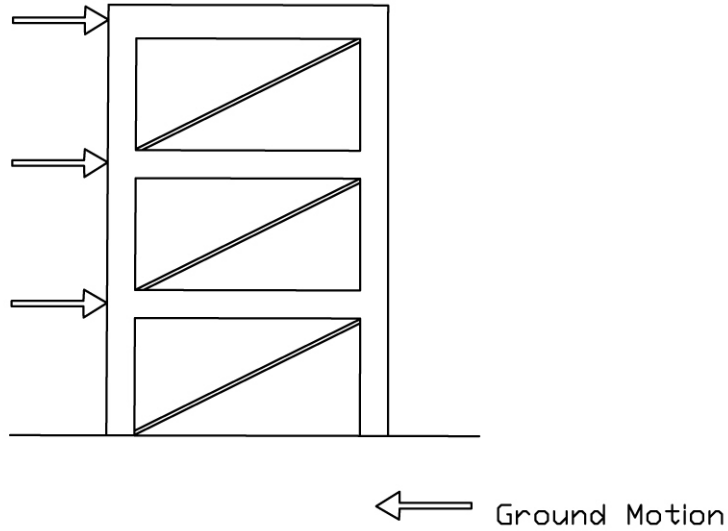

Figure 7a  
Diagonal Bracing  
Chevrons en diagonal

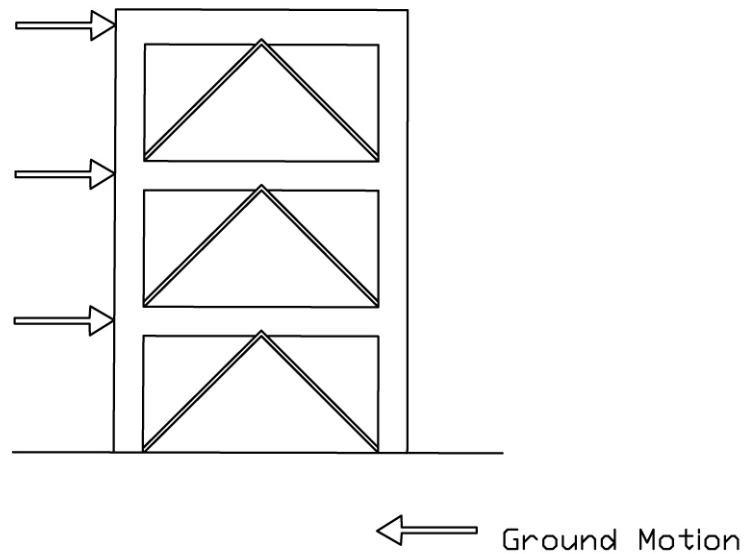

Figure 7b  
Chevron Bracing  
Exemple de chevronnage

### 3.2- Roof Shapes and Slopes for Hurricanes

- A hip-roofed home of a cubical form is considered as one of the best configurations to use in high wind or hurricane prone areas. Research by wind engineers has shown that a hip roof (4 slopes) performs better than a gable roof (2 slopes) under wind forces. Gable roofs are generally more common because they are cheaper to build.
- An optimal roof slope was estimated by wind researchers to be around 30 degrees. On a single-slope roof, important slopes generally lead to important uplift forces and should be avoided.
- Homes with a double-span roof are common in some areas of the Caribbean. For such roofs, it is important to structurally disconnect the two roofs. If not, the collapse of one roof might trigger a failure in the other leading to a more generalized failure in some cases. Structural failure takes often the shape of a progressive process where the collapse of one element leads to the failure or collapse of another. A roof collapse might therefore trigger a chain reaction causing a progressive collapse of a structure.
- In order to reduce wind uplift forces on the roof, an opening in a zone of negative wind pressure (suction) would be helpful to alleviate wind pressures on the roof, and help balance internal and external pressures. In high winds or hurricane prone areas, designers might want to consider some roof openings that would promote

natural ventilation under regular warm conditions, and help reduce wind pressures on the roof in high wind conditions. The best locations for such openings would be close to the ridge. The ridge is generally considered as the location of largest depression on a roof. Some means of protecting the interior from possible rains should however be adopted in these cases. An example is suggested by CSTB, Centre Scientifique et Technique du Bâtiment (Center for Building Science and Technology), at Nantes, France, and is given in Figure 8.

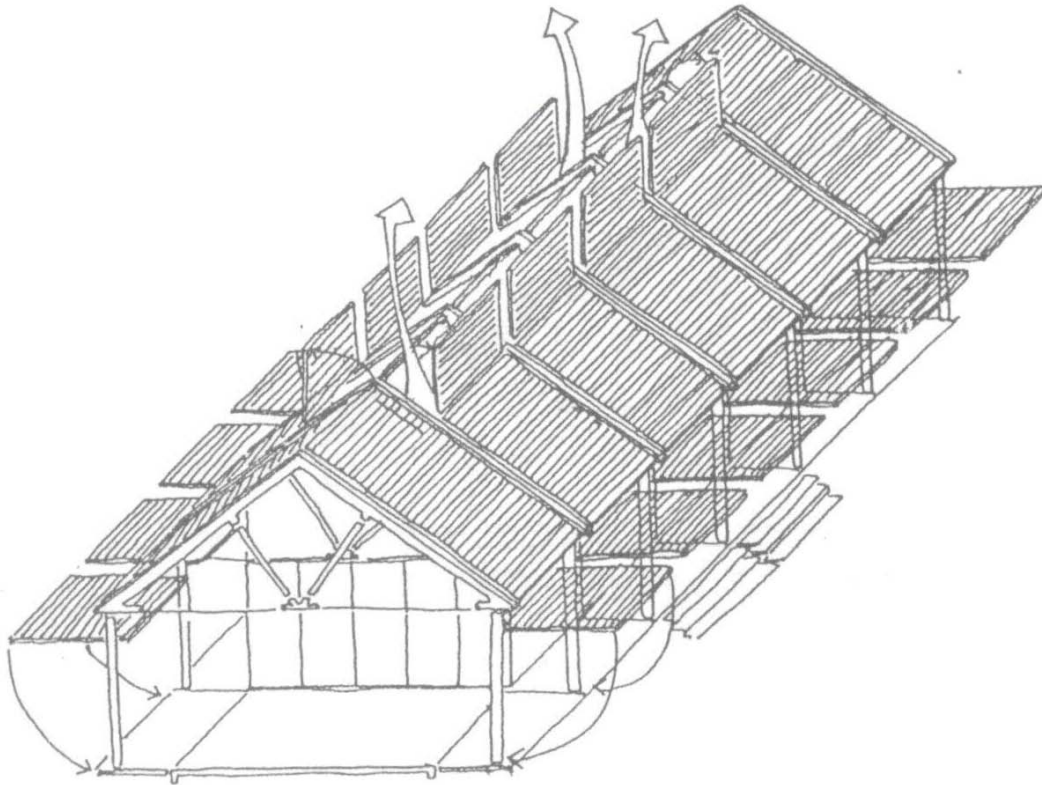

Figure 8

Roof Openings Could Be Used to Reduce Wind Pressure

Concept Proposed by CSTB

Centre Scientifique et Technique du Bâtiment, Nantes, France

Un puits de dépression en toiture aiderait à équilibrer les charges en période cyclonique (CSTB)

- Porch roofs and overhangs are often subject to high wind uplift forces. It is recommended to structurally disconnect them from the main structure, if possible, especially at the roof level. A collapse of these elements can trigger a wider roof failure. It is also recommended to keep roof overhangs relatively short as shown in Figure 9 (20 in. or about 50 cm).

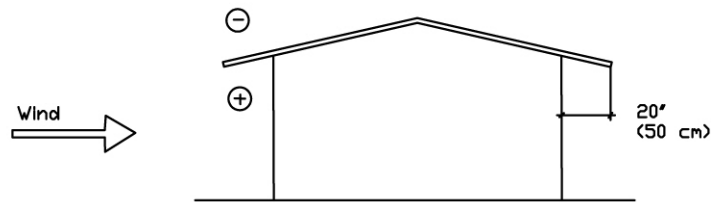

Figure 9  
Roof Overhangs Must Be Kept Short  
Le prolongement de la toiture devrait être limité

- For long overhangs, and as an example, wind researchers from CSTB suggest providing an opening as shown in Figure 10, of a width not exceeding 1/3 of the total overhang length in order to help reduce wind pressure.

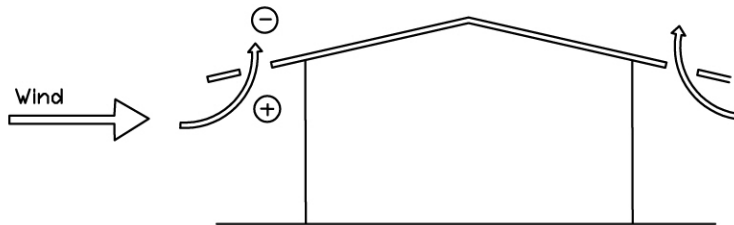

Figure 10  
Openings in Long Overhangs Help Reduce Wind Pressure (CSTB)  
Dans un long débord de toiture, une fente permettrait de réduire les charges (CSTB)

- A roof's lower edge is generally subject to some large localized wind pressures. Research and testing of reduced scale models in wind tunnels showed the efficiency of the following edge treatment systems as proposed by wind engineers at the CSTB center of Nantes, France:
  - 1- A horizontal grid 20 to 24 inches wide (50 to 60 cm) similar to sun-visor louvers (Figure 11a) to be placed along the perimeter of the home and attached to the vertical structure (not the roof).
  - 2- A notched frieze installed at the level of the gutters, along the perimeter of the home, and expected to reduce the roof edge depression by acting as a vortex generator (Figure 11b).

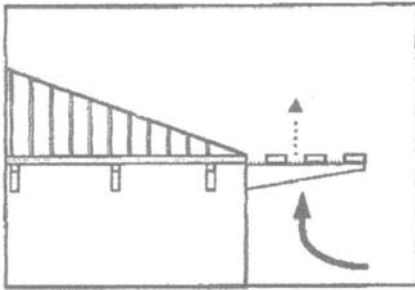

Figure 11a

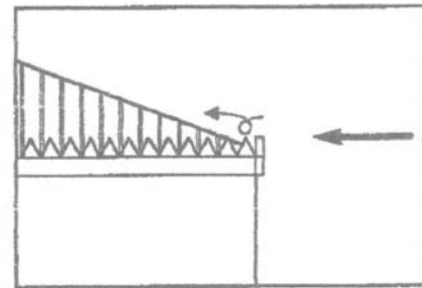

Figure 11b

Figure 11

### Roof Edge Treatment Systems Proposed by CSTB

#### Systèmes de protection cyclonique des rives de toiture proposés par le CSTB

Based on the wind tunnel tests carried out at CSTB, the use of these suggested roof edge treatment systems could lead to a reduction in the localized wind loads on roof edges by a factor of 1.5 to 2.

- In order to reduce wind loads on porch roofs, wind researchers at CSTB, Nantes, recommend two systems as illustrated in Figure 12. The first system consists in dividing the porch roof into 3 equal panels that are swiveled to make an angle of  $40^\circ$  with the horizontal. Each panel is about 39 inches wide (1 m). The second system consists of vertical slats 6 to 8 inches wide (15 to 20 cm). These systems operate in two positions: closed for normal weather conditions and open for hurricane conditions.



Figure 12

### Porch Roof Systems Proposed by CSTB Véranda cyclonique proposée par le CSTB

#### **3.3- Construction Materials and Methods**

- Keep the same construction type for the full height of the structure. Observations from past earthquakes show that buildings often collapse at the level of junction of two different construction methods.

- Use good quality construction materials. Good materials make a building safer and resist forces of wind and earthquake better.
- Avoid using unreinforced masonry. It is recommended to use partially or fully reinforced and grouted masonry. Reinforcement is generally introduced vertically as well as horizontally between beds of masonry to help tie the blocks together.
- The quality of mortar used in masonry construction is important, because it binds the blocks together and prevents them from moving. Water and sand used to mix a mortar should be both clean. Sand should not contain clay. Lime and cement used for mortar should also be of good quality.
- The tops of masonry walls must be tied together by a continuous ring or bond beam (Figure 13). A bond beam is often cast inside a U-shaped concrete block and reinforced with rebars, or it could also be made of reinforced site-cast concrete into a wooden formwork. The bond beam must be securely fastened to the walls and floor or roof. Rebars in this beam must be well-protected with an adequate cover, and any roof joists or trusses must be well anchored to the bond beam.
- Connect masonry walls at the corners strongly by adding reinforcing bars in the horizontal joints. One of the most common types of failure is a wall connection failure at the corners. When walls are not connected adequately at the corners, they tend to move separately leading to failure.

#### Materials for Roofs, Doors and Windows

High winds could cause great damage to roof covering systems which could lead to water infiltration and important damages to the interior of a building and its contents. Different types of roof coverings are used. Some systems perform better than others under hurricane conditions.

Some of the most common types of roof coverings are: tiles, slate, wood shingles and shakes, metal panels and metal shingles, asphalt shingles, cement-fiber shingles, and liquid-applied membranes. A detailed discussion of the performance of these systems is given by FEMA, Federal Emergency Management Agency in its Coastal Construction Manual (<http://www.fema.gov>).

- In general, tile roof coverings are brittle and have a weak resistance to breakage from windborne missiles. Post-disaster investigations in the US showed a poor performance of wire-tied systems, and the performance of mortar-set tile systems in Florida during Hurricane Andrew was found to be poor as well. Loose tile has also the potential of becoming windborne debris and the cause of damage to other buildings.

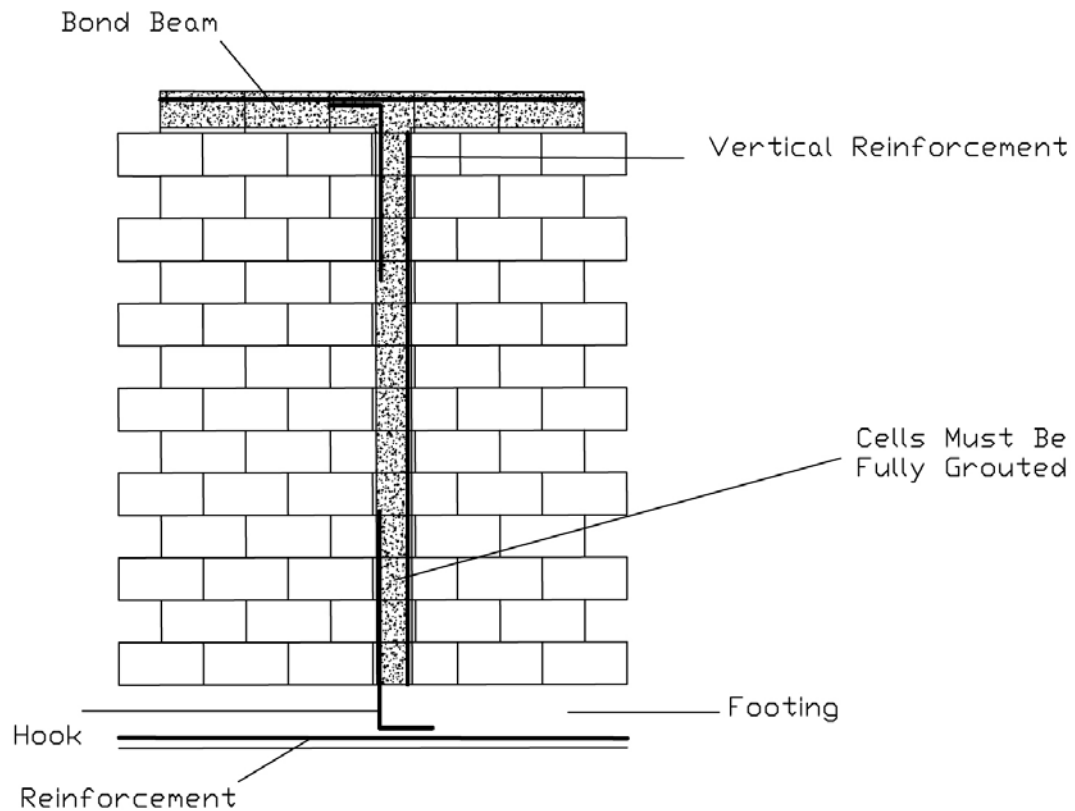

Figure 13  
A Detail Example of a Bond Beam and Reinforcement  
Exemple d'un chaînage et renforcement en maçonnerie

- Post-disaster investigations of hurricane events in the US also showed that properly attached wood shingles and shakes can perform well. Slate has a limited use in the hurricane prone areas of the US and therefore, few data is available on its performance under hurricane conditions.
- Exterior doors are generally subject to positive or negative wind pressures and they should be strong enough to resist these pressures. In areas close to the ocean, doors should be protected from corrosion. Doors made of aluminum or painted galvanized steel units are generally recommended. Designers and builders should pay attention to water leakage problems which generally occur between the door and its frame.
- Windows and skylights should be strong enough to resist wind pressures and possible breakage from windborne missiles. All glazing must be protected using

hurricane shutters. Sealants must be properly used to protect from water leakage problems.

- Windborne debris driven by hurricane wind speeds become projectiles and missiles greatly threatening glazed building surfaces. It is therefore important to protect all glazing using sturdy shutters.
- Hurricane shutters could be constructed using plywood panels or wooden boards. It is recommended to attach them to the wall and not to the window frame, and to set them far enough from the glazing.

### **3.4- Foundation Systems for Coastal Areas**

In coastal areas, foundations are at risk from wind forces, hurricane-driven waters, flooding, wave action and waterborne debris. Wave action can cause scour. A frequent type of failure during hurricanes is the flotation of a home from its foundation due to flood waters, especially when homes are poorly attached to the foundation.

- Elevating a structure on an open foundation or piles reduces the risk of damage from flooding.
- It is necessary to increase the penetration depths of piles into the ground. Soil conditions are important for foundation design. Sand is a common soil type in most coastal hurricane prone regions. In severe storms, the scour depth in sandy soils can be several feet. Clay is found under a layer of sand in some areas. Clay offers a larger capacity with less penetration compared to sand, and is less affected by scour.
- Piles must be braced to better resist lateral forces. Knee or diagonal bracing could be used (Figures 14 and 15). Truss bracing is also an option, and is generally recommended when the building is elevated more than 10 ft (3 m), or for high wind speeds.
- Horizontal bracing or grade beams could also be used to increase pile resistance (Figure 16). They consist of horizontal members placed around the perimeter of the building, and connecting piles at ground level. However, the use of grade beams has been occasionally criticized. Some engineers think that their use may result in increased scour and wave forces around the foundation.

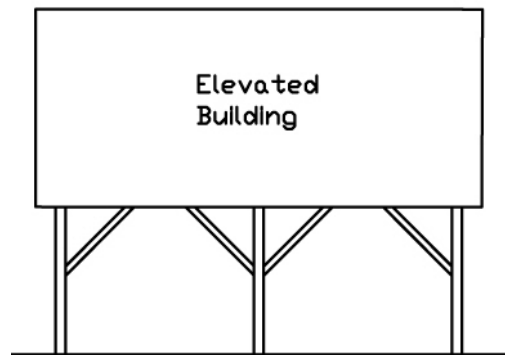

Figure 14  
Knee Bracing of Piles  
Bâtiment sur pilotis – Exemple de chevronnage

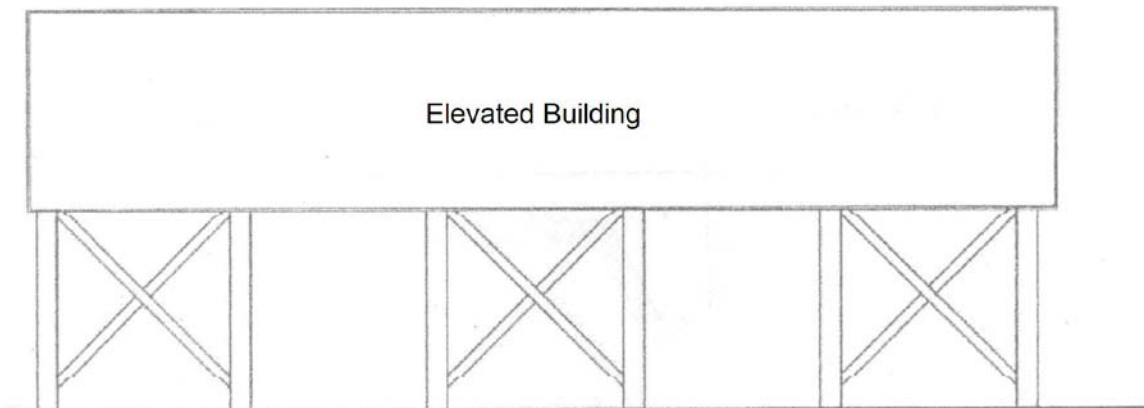

Figure 15  
Diagonal Bracing of Piles  
Bâtiment sur pilotis – Chevrons en diagonal

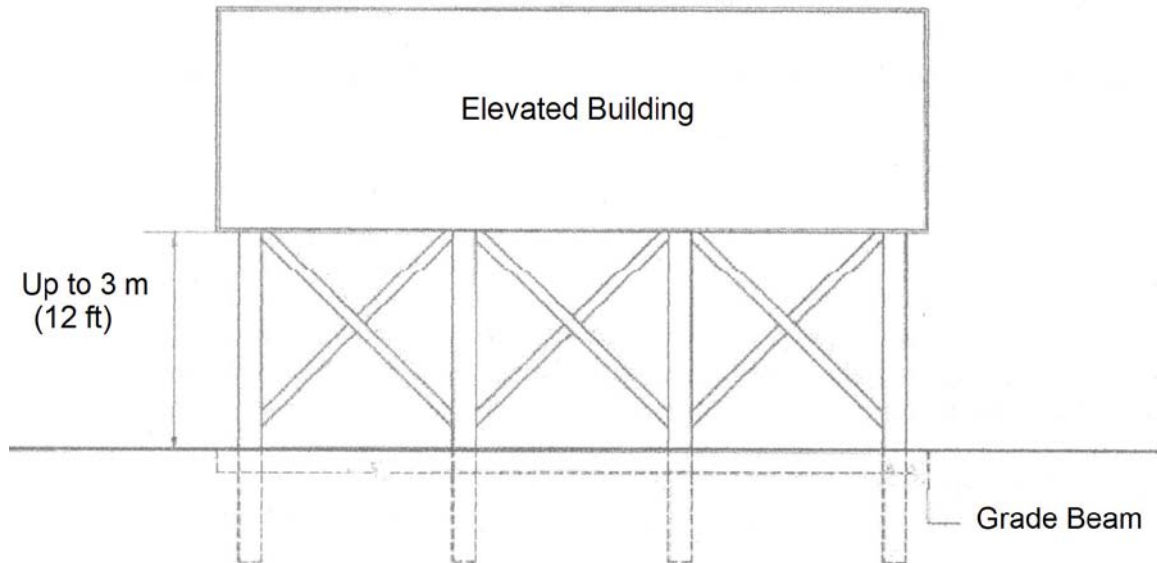

Figure 16  
Truss Bracing of Piles  
Bâtiment sur pilotis – Chevrognage en treillis

### **3.5- Jobsite Safety Issues**

The following is a short summary of some of the most important construction site safety measures. In the US, the Occupational Safety & Health Administration (OSHA) of the US Department of Labor has a number of standards that construction jobs are supposed to comply with. More information could be obtained through the OSHA website at <http://www.osha.gov>.

- Construction site employees are expected to wear personal protective equipment or PPE, designed to protect from serious injuries or illness resulting from contact with workplace hazards. These include hard hats, safety shoes, face shields, and safety glasses, in addition to a variety of devices and garments such as gloves, earplugs, vests and respirators.
- An employer is expected to conduct a hazard assessment of the jobsite to determine what hazards are present that require the use of PPE and provide workers with appropriate PPE that should be maintained in a sanitary and good condition.
- PPE is considered the last line of defense after engineering and administrative controls. These controls generally involve work practices, scheduling work and rotating employees to reduce exposure, as well as training workers on how to perform tasks safely.
- First aid services and provisions for medical care should be made available.

- An effective fire protection and prevention program must be maintained.
- Keep work areas and passageways clear from construction debris and scrap metal or lumber (especially with protruding nails).
- Separate waste and use covered containers for garbage and other oily, flammable and hazardous wastes, and dispose of such wastes regularly.
- Construction areas and other work areas must be properly lit.
- Buildings and structures should be maintained free of obstructions, and exits must be marked by visible signs.
- Provide an adequate supply of potable water.
- Use accident prevention signs and tags such as danger and caution signs, and safety instruction signs.
- All hand and power tools must be maintained in a safe condition. Electric power operated tools must be grounded or of the double-insulated type.
- Scaffolding must be designed by a qualified person. As a general rule, scaffold components must be capable of supporting their own weight and at least 4 times the maximum intended load applied or transmitted to them.
- Hook-on and attachable ladders should be properly positioned and inspected.
- Ramps and walkways should be inclined by no more than 20 degrees above the horizontal (slope: 1 vertical to 3 horizontal).
- All rigging material must be inspected and defective equipments must be removed.

### **3.6- Sustainability**

Green initiatives cover many issues including site-work protection, the use of efficient HVAC systems and alternative energy sources, as well as the selection of building materials. All members of a project team are generally expected to contribute.

The following is a summary of green guidelines for the selection of construction materials and methods:

- Cut down on construction costs by using materials that are locally available, and avoid imported sources of cement and other construction materials, if possible.
- Use recycled materials whenever possible. Examples include fly-ash concrete and some composite wood products that can have various levels of recycled materials.
- Apply construction practices that reduce the amount of waste. Use materials that are delivered as completely assembled products thus avoiding generating wastes from the cutting of products. Examples of prefabricated products are steel beams, precast concrete components, masonry and concrete blocks.
- Use material sources that can be reused in the future in case of demolition or renovation. Generally, wood products could be reused as siding material and steel and precast components can be disassembled and salvaged.
- Use durable adaptable materials, and design buildings and structures in ways that can adapt to a future expansion.
- Design for daylighting to cut down on energy costs for artificial lighting.
- Include passive systems and use design strategies such as passive solar design, to reduce the reliance on active systems.
- Consider life-cycle costs versus lower initial costs in design and construction.

### 3- References

- 1 Betbeder- Matibet, J., (2008). "Seismic Engineering." Wiley & Sons.
- 2 Davenport, A.G., Meecham, D., and Surry, D. (1991). "The Magnitude and Distribution of Wind Induced Pressures on Hip and Gable Roofs." *J. of Wind Eng. and Industrial aerodynamics*, 38, 257-272.
- 3 Edinger, P. H., Gould, J.P., Krinitzsky E. L., (1993). "Fundamentals of Earthquake-Resistant Construction." Wiley & Sons.
- 4 Erdy, C. K., (2007). "Earthquake Engineering Application to Design." Wiley & Sons.
- 5 FEMA, Federal Emergency Management Agency (2000). "Coastal Construction Manual, 3<sup>rd</sup> Edition."

- 6 FEMA, Federal Emergency Management Agency (1993). "Lessons of Hurricane Andrew, Excerpts from the 15<sup>th</sup> Annual National Hurricane Conference, April 13-16, 1993, Orlando, Florida." FEMA, Washington, D.C.
- 7 FEMA, Federal Emergency Management Agency (1999). "Oklahoma and Kansas, Midwest Tornadoes of May 3, 1999 – Observations, Recommendations, and Technical Guidance." FEMA 342/ October 1999, Washington, D.C.
- 8 Gandemer, J., and H elary-Moreau, S. (1999). "Wind Loads and Architectural Design - Application to Tropical Cyclonic Dwelling." *Proc. 10<sup>th</sup> Int. Conf. On Wind Eng., Wind Engineering into the 21st Century*, Copenhagen, Denmark, 1401-1408, Edited by Larsen , Larose & Livesey published by A.A. Balkema, Rotterdam, Brookfield.
- 9 Hessig, M. L. (1986)." A Wind Tunnel Study of Roof Loads on Common Residential Structures." Master's Thesis, Clemson University.
- 10 Holmes, J. D. (1994). "Wind Pressure on Tropical Housing." *J. of Wind Eng. and Industrial Aerodynamics*, 53, 105-113.
- 11 Holmes, J. D. (2003). "Emerging Issues in Wind Engineering, Part 1." *The Wind Engineer*, American Association for Wind Engineering, Issue of July 2003, 8-10.
- 12 Holmes, J. D. (2003). "Emerging Issues in Wind Engineering, Part 2." *The Wind Engineer*, American Association for Wind Engineering, Issue of September 2003, 1-8.
- 13 Kibert, C. J. (2009). "Sustainable Construction, Green Building Design and Delivery." Wiley & Sons.
- 14 Letchford, C. and Morse S. M. (2003). "Wind Pressures around Non-Rectangular Plan-form Buildings." *Proc. of the 11<sup>th</sup> International Conference on Wind Engineering*, hosted by Texas Tech university, Lubbock, Texas, 973- 980.
- 15 Meecham, D. (1988). "Wind Action on Hip and Gable Roofs." Master's Thesis, University of Western Ontario, Ontario, Canada.
- 16 Reardon, G. F., and Xu, Y. L. (1997). "Effects of Roof Slope on Wind Pressures of a Hip Roof." *Proc. 4<sup>th</sup> Asia-Pacific Symp. On Wind Engineering*, Gold Coast, Australia, 147-150.
- 17 Taher, R., (2007). "Design of Low-Rise Buildings for Extreme Wind Events." *J. of Architectural Eng. Of the American Society of Civil Engineers*, March 2007.
- 18 Taher, R. (2009). "Improved Building Practices for Hurricanes." *Caribbean Construction Magazine*, July 2009.